

Cognitive Sub-Nyquist Radar for Automotive Application

Gilad Feinberg
Harel Moalem

Roe Katz
Eli Laks

Satish Mulleti
Eli Shoshan

Kumar Vijay Mishra
Zora Slavik

Andrey Zhitnikov
Yonina C. Eldar

Motivation and Contributions

- High resolution radar requires high bandwidth signals
- Wideband signals need a complex analog front end receiver design which consumes high power
- Digital processing of wideband signals requires large memory and large computational power
- We present a sub-Nyquist cognitive radar prototype for automotive application where the sampling and recovery method implemented in hardware which reduces the rate by 20 fold
- This approach provides both simple recovery and robustness to noise by performing beamforming on the low rate samples
- For automotive applications, simultaneous transmission of multiple vehicles is achieved by cognitive band selection. This also aids in robust reconstruction

Sub-Nyquist Radar

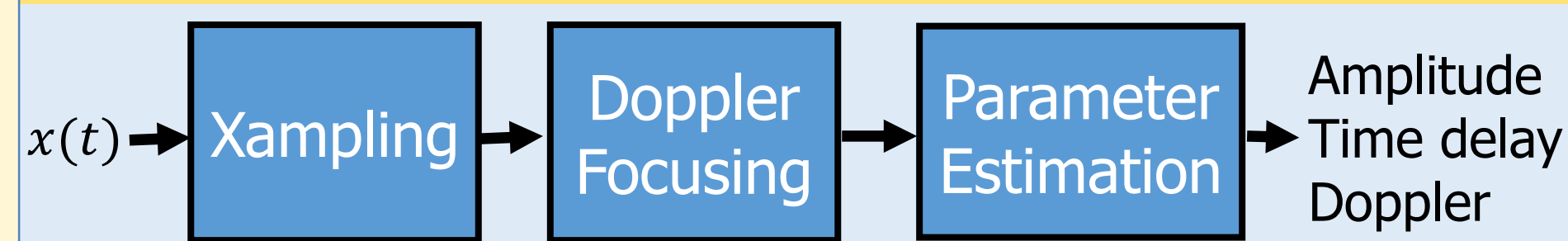

- Xampling**– A process of sampling a signal at a low rate in such a way that preserves the required information.
- Doppler Focusing** - A method of digitally beamforming the low rate samples which is both numerically efficient and robust to noise.
- Estimation** – A modified OMP, matched to our samples, produces target locations and Doppler frequencies.

Signal Model and Recovery

- L targets, each defined by 3 degrees of freedom: amplitude α_ℓ , delay τ_ℓ , and Doppler frequency ν_ℓ .

- After transmitting P equispaced high-bandwidth pulses $h(t)$, the received signal:

$$x(t) = \sum_{p=0}^{P-1} \sum_{l=0}^{L-1} \alpha_l h(t - \tau_l - p\tau) e^{-j\nu_l p\tau}$$

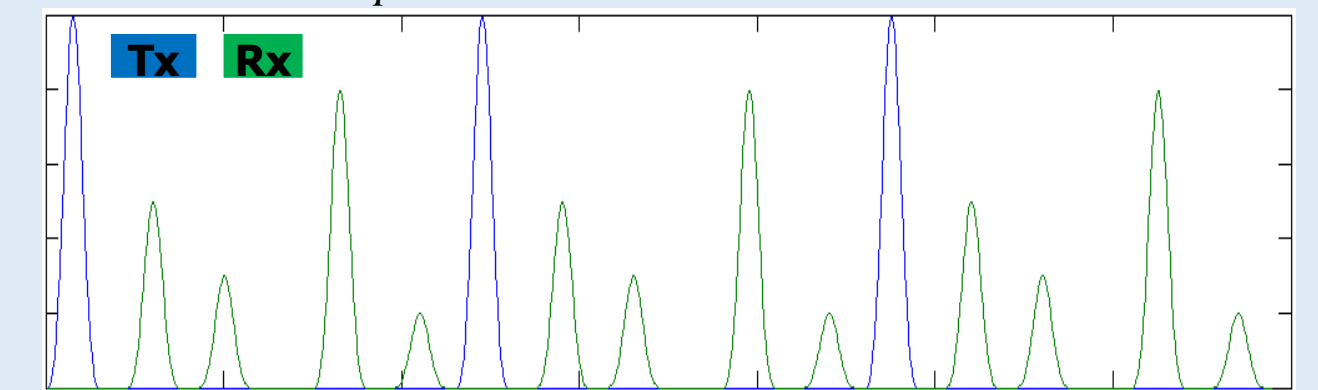

- This is an FRI model as $x(t)$ is completely defined by $3L$ parameters
- The signal's Fourier coefficients contain the required parameters.

Acquiring Fourier Coefficients

- Multichannel analog processing and low rate sampling scheme are used to extract spectral information for specific frequency bands.
- Calculating Fourier coefficients is performed digitally after sampling

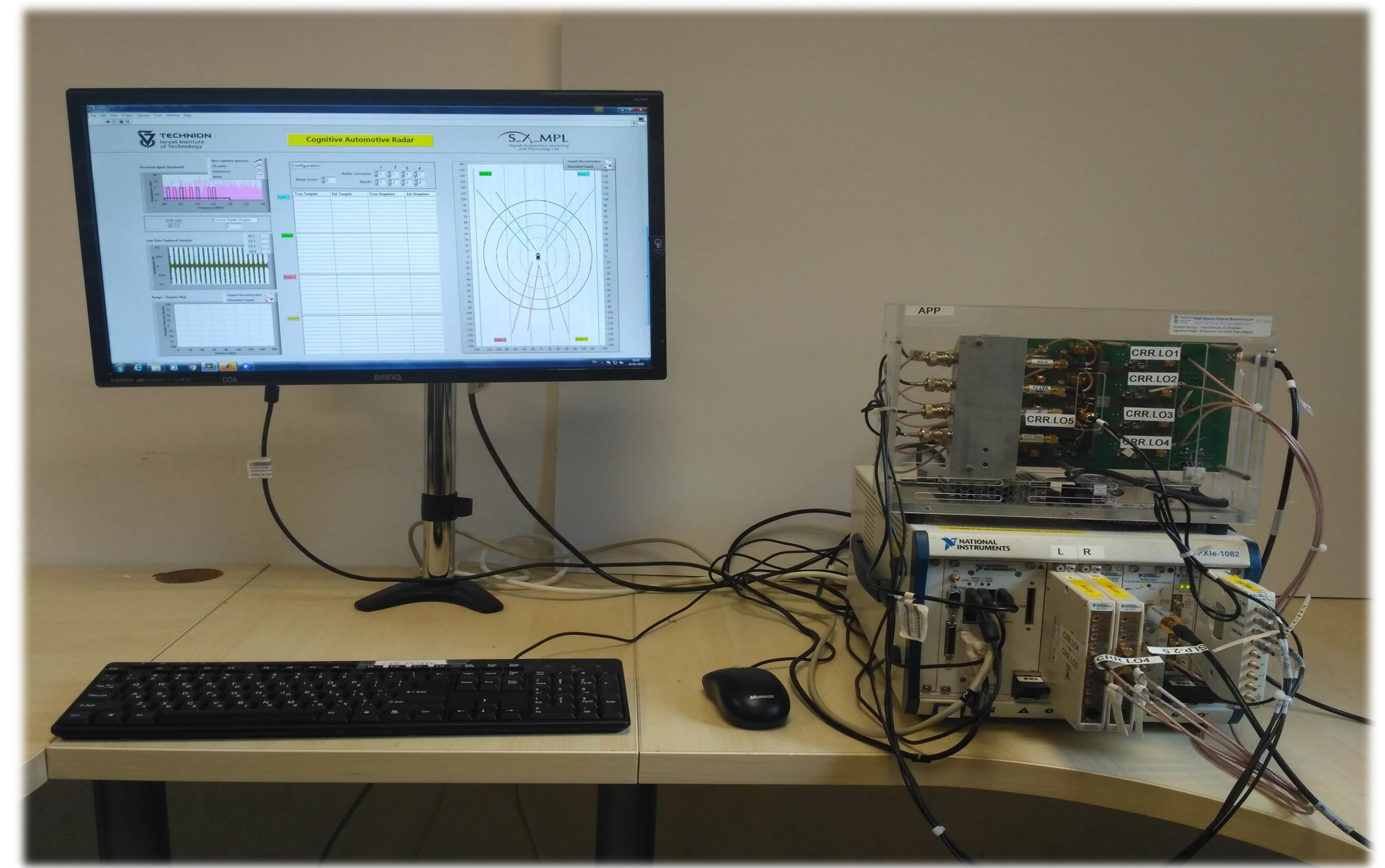
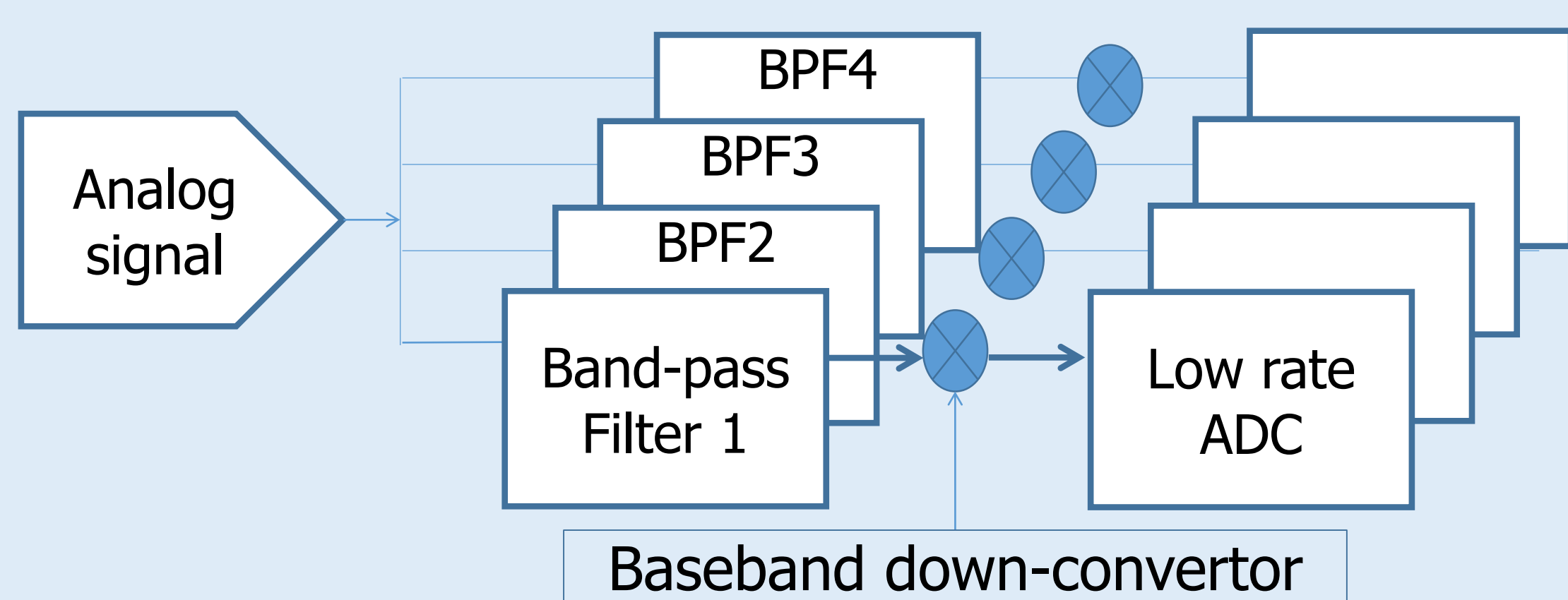

Radar Bands

- Four radars transmit sequentially in four different directions.
- Available bandwidth is 2 MHz; Divided into 16 sub-bands of 80 KHz bandwidth.
- Each radar transmits in four random sub-bands to avoid interference.
- Each of the sub-bands are sampled individually at 250 KHz.

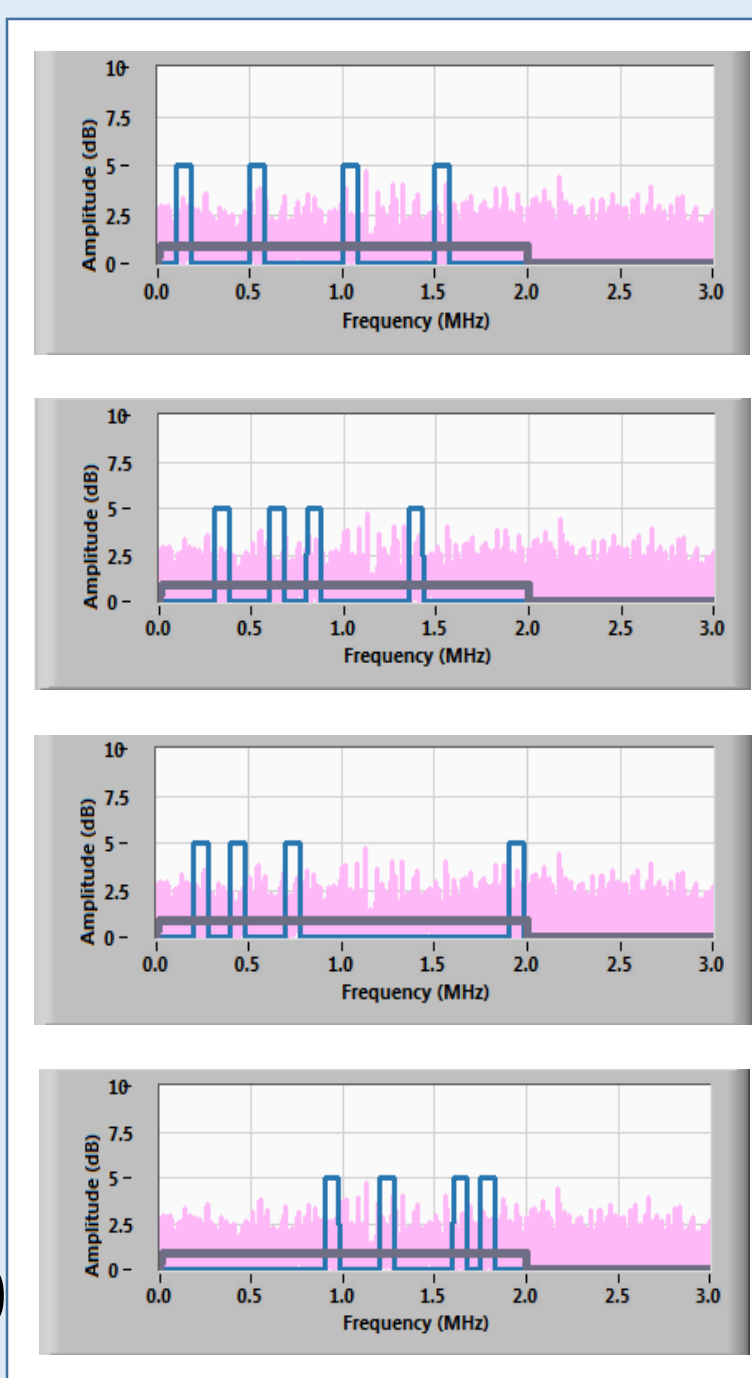

Analog Pre-Processor (APP)

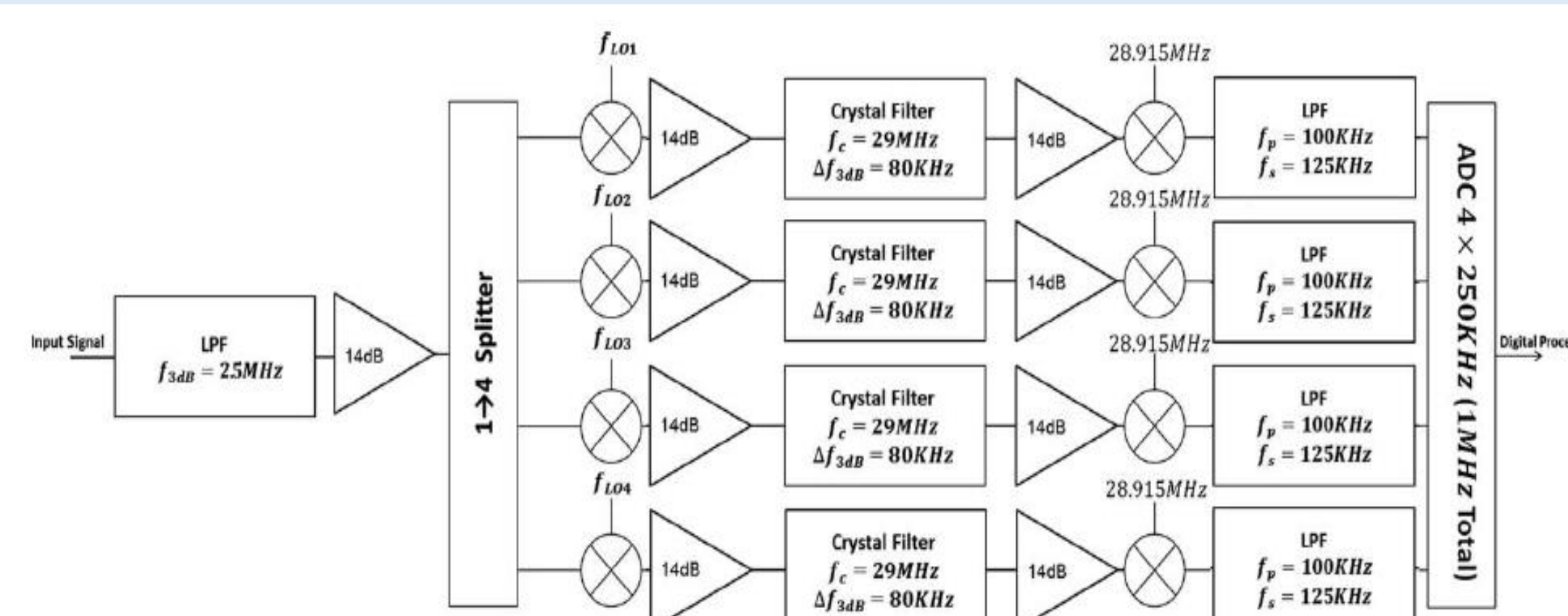

Block diagram of 4-channel crystal receiver. Four up-modulating LOs have frequency values: $f_{LO1} = 28.375$ MHz, $f_{LO2} = 28.275$ MHz, $f_{LO3} = 27.65$ MHz, $f_{LO4} = 27.391$ MHz.

Crystal Bandpass Filter Characteristics

| Parameter | Value |
|------------------------------|----------------------|
| Center Frequency | 29 MHz |
| -3dB Bandwidth | 80 KHz |
| Maximal Pass-band Ripple | 1 dB |
| Stopband Frequencies | 28.94 MHz, 29.06 MHz |
| Minimal Stopband Attenuation | 60 dB |

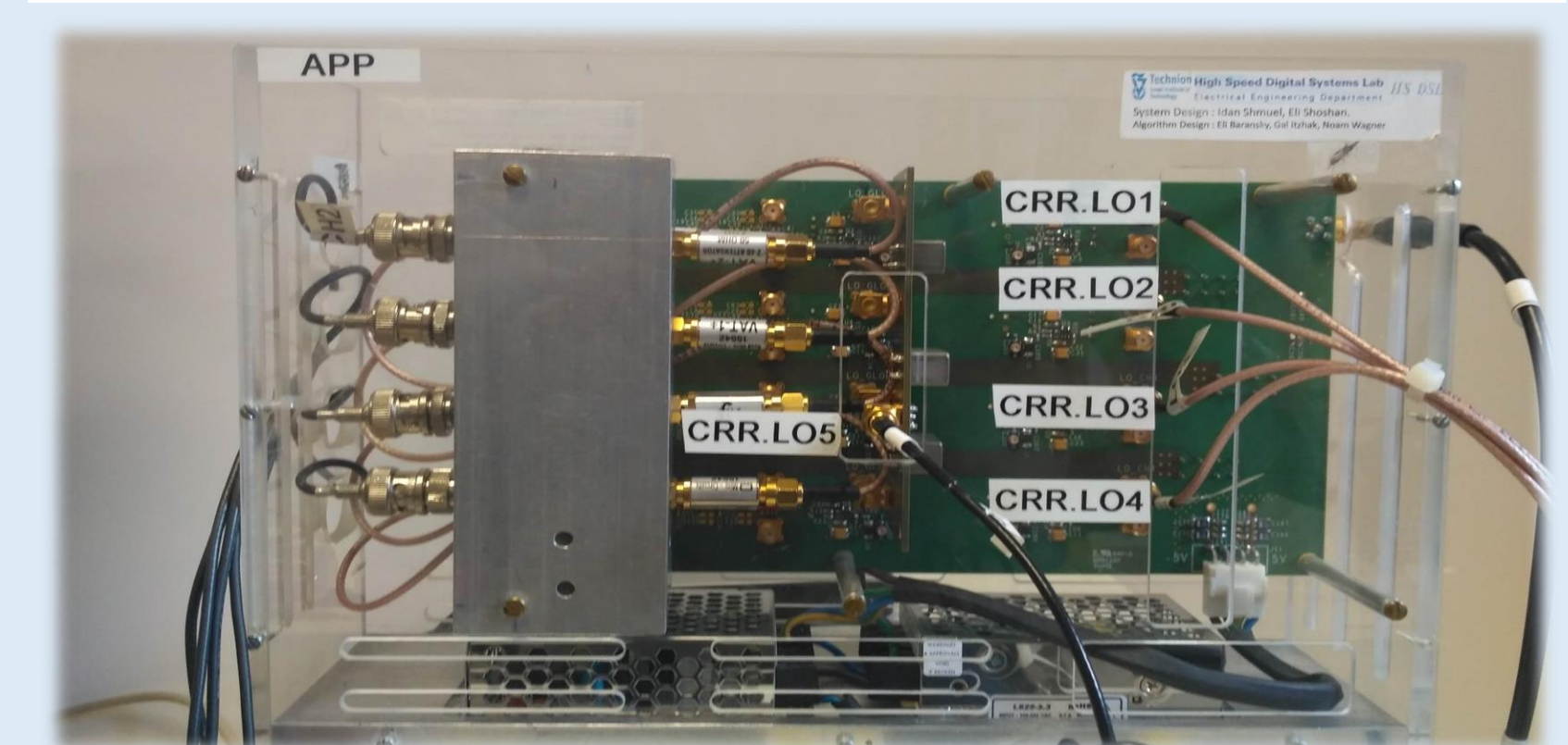

User Interface

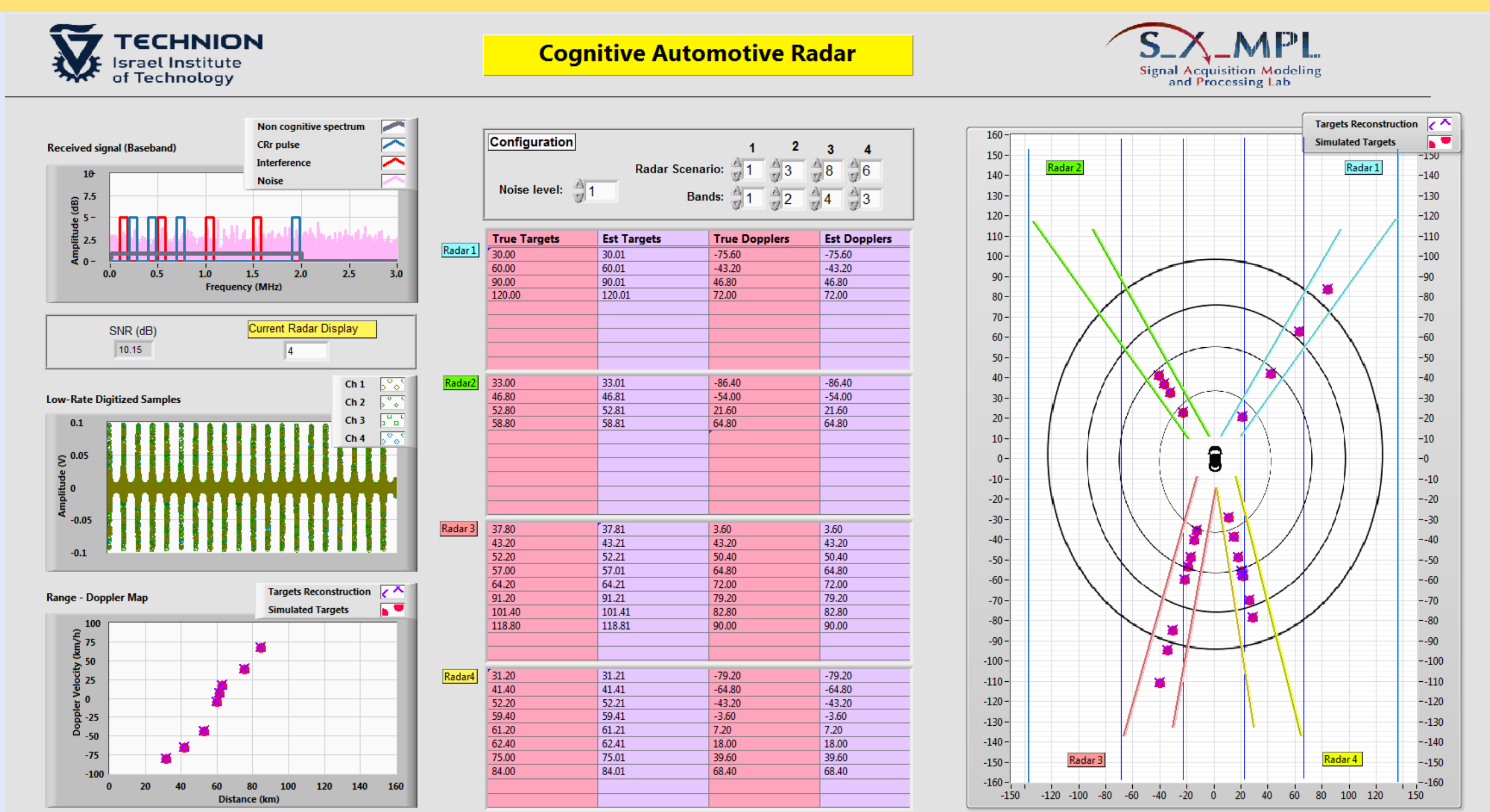

Results

